

Podstawa montażowa pod rozdzielacz sterujący

Podstawa montażowa pozwala na montaż rozdzielacza pneumatycznego lub elektrorozdzielacza na obudowie siłownika. Podstawa jest mocowana do szpilek siłownika (lub do pseudo-szpilek na profilu). Montowane rozdzielacze mogą być z wejściami gwintowanymi lub w wersji pod bazę ISO. Wszystkie otwory mocujące są gwintowane i gotowe do montażu rozdzielaczy PNEUMAX serii 828-858/2-414/2-824 oraz baz dla rozdzielaczy standardu ISO rozmiaru 1 i 2.

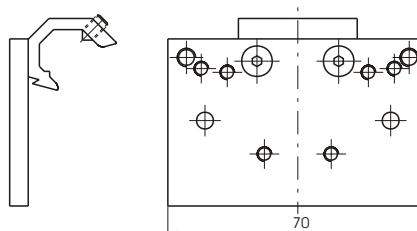

Kod zamówieniowy	1306.15 1320.15 1320.16 1320.17 1320.18 1320.19 1320.20	Typy siłowników szpilekowe (Ø 32-Ø 100) z tuleją kształtową (Ø 32-Ø 40) z tuleją kształtową (Ø 50-Ø 63) z tuleją kształtową (Ø 80-Ø 100) z tuleją kształtową (Ø 125) z tuleją kształtową (Ø 160) z tuleją kształtową (Ø 200)
------------------	--	---

Bazy dla rozdzielaczy ISO

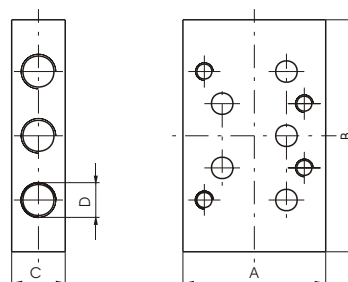

Kod zamówieniowy	Wymiary			
	A	B	C	D
1320.21 baza dla rozdzielacza ISO rozmiar 1	40	75	15	G 1/8"
1320.22 baza dla rozdzielacza ISO rozmiar 2	50	95	20	G 1/4"

Flansze tylne i przednie (MF1 - MF2)

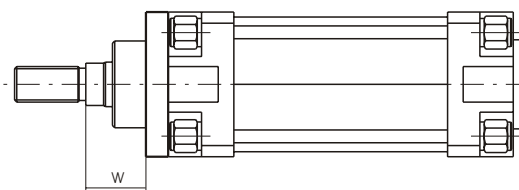
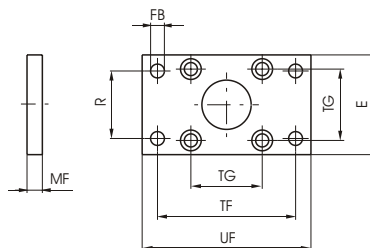

Przednia

Flansze pozwalają na zamocowanie siłownika pod kątem prostym do powierzchni. Wykonane są ze stali ocynkowanej.

Tylna

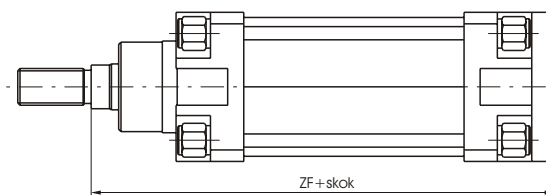

Średnica	32	40	50	63	80	100	125	160	200
E	45	52	65	75	95	115	140	180	220
FB (H 13)	7	9	9	9	12	14	16	18	22
MF (JS 14)	10	10	12	12	16	16	20	20	25
R (JS 14)	32	36	45	50	63	75	90	115	135
TF (JS 14)	64	72	90	100	126	150	180	230	270
TG	32,5	38	46,5	56,5	72	89	110	140	175
UF	80	90	110	120	150	170	205	260	300
ZF	130	145	155	170	190	205	245	280	300
W	16	20	25	25	30	35	45	60	70
waga gr.	190	250	480	620	1430	1990	3750	6350	11350

Kod zamówieniowy	
Przednia	1320.Ø.03F
Tylna	1320.Ø.04F

Stopy standardowe (długie)

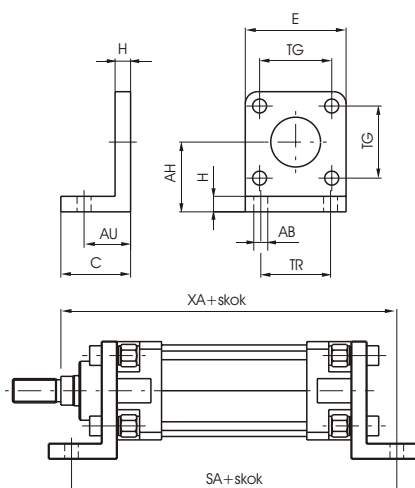

Element pozwalający na zamocowanie siłownika równoległe do płaszczyzny. Wykonane z aluminium, pokryte czarnym lakierem.

Średnica	32	40	50	63	80	100	125	160	200
AB (H 14)	7	9	9	9	12	14	16	18	22
AH (JS 15)	32	36	45	50	63	71	91	115	135
AU (±0,2)	24	28	32	32	41	41	45	60	70
C	35	35	45	45	55	56	68	82	90
E	45	52	65	75	95	115	140	180	220
H	8	8	10	10	12	12	16	20	20
SA	142	161	170	185	210	220	250	300	320
TG	32,5	38	46,5	56,5	72	89	110	140	175
TR (JS 14)	32	36	45	50	63	75	90	115	135
XA	144	163	175	190	215	230	270	320	345
waga gr.	45	65	140	175	360	470	920	2300	3200

Kod zamówieniowy

1320.Ø.05F (1 sztuka)

Stopa mocująca, krótka (kształtka metalowa MS1)

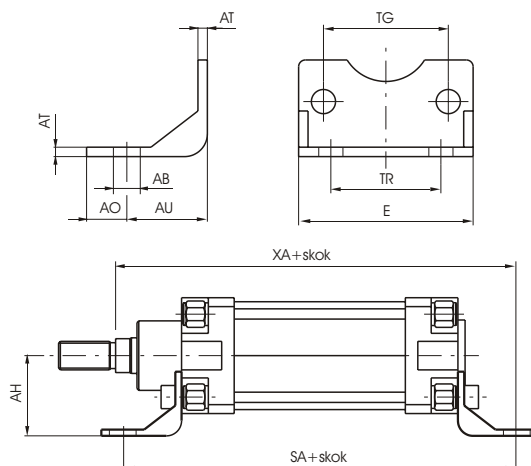

Element do montażu siłownika równoległe do płaszczyzny. Wykonane z tłoczonego metalu lakierowanego na czarno.

Średnica	32	40	50	63	80	100	125	160	200
AB (14)	7	9	9	9	12	14	16	18	22
A (S 15)	32	36	45	50	63	71	90	115	135
AU (±0.2)	24	28	32	32	41	41	45	60	70
AO (±0.2)	11	8	15	13	14	16	25	15	30
E	45	52	65	75	95	115	140	180	220
AT	4	4	5	5	6	6	8	9	12
SA	142	161	170	185	210	220	250	300	320
TG	32,5	38	46,5	56,5	72	89	110	140	175
TR (S 14)	32	36	45	50	63	75	90	115	135
XA	144	163	175	190	215	230	270	320	345
waga gr.	65	80	170	190	380	450	1090	1190	3450

Kod zamówieniowy

1320.Ø.05/1F (1 sztuka)

Kołnierz przedni

(nie występuje w specyfikacji standardu ISO)

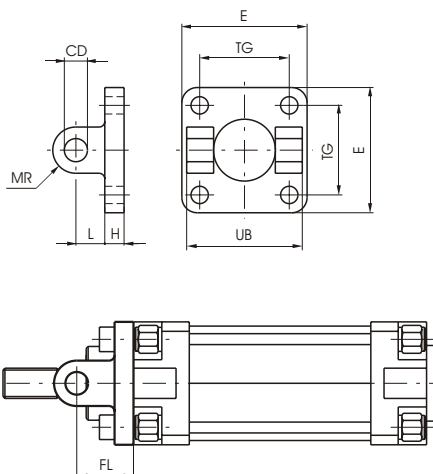

Umożliwia mocowanie siłownika równoległe lub pod kątem prostym do płaszczyzny. Pozwala na samoosiowanie się siłownika pod obciążeniem. Wykonany ze stopu aluminium pokryty czarnym lakierem.

Kod zamówieniowy	
	1320.Ø.08F

Średnica	32	40	50	63	80	100	125	160	200
CD (H 9)	10	12	12	16	16	20	25	30	30
E	45	52	65	75	95	115	140	180	220
FL (±0,2)	22	25	27	32	36	41	50	55	60
H	9	9	11	11	14	14	20	20	25
L	13	16	16	21	22	27	30	35	35
MR	10	12	12	16	16	20	25	25	25
TG	32,5	38	46,5	56,5	72	89	110	140	175
UB (h 14)	45	52	60	70	90	110	130	170	170
waga gr.	50	75	125	190	380	620	1180	1780	2900

Kołnierz tylny ze sworzniem (MP2)

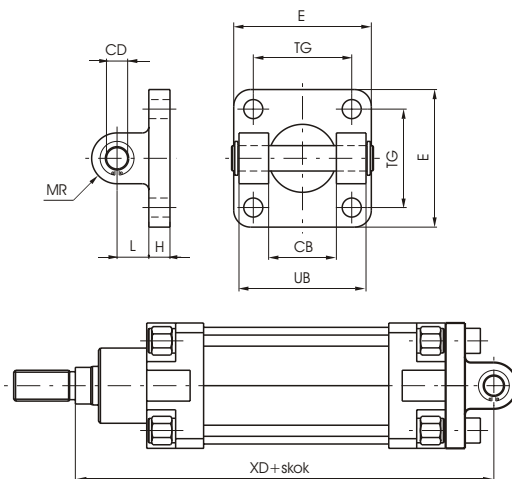

Podobnie jak element 08 umożliwia mocowanie siłownika równoległe lub pod kątem prostym do płaszczyzny. Posiada dodatkowo sworznię. Pozwala na samoosiowanie się siłownika pod obciążeniem. Wykonany ze stopu aluminium pokryty czarnym lakierem.

Kod zamówieniowy	
	1320.Ø.09F

Średnica	32	40	50	63	80	100	125	160	200
CB (h 9)	26	28	32	40	50	60	70	90	90
CD (H 9)	10	12	12	16	16	20	25	30	30
E	45	52	65	75	95	115	140	180	220
H	9	9	11	11	14	14	20	20	25
L	13	16	16	21	22	27	30	35	35
MR	10	12	12	16	16	20	25	25	25
TG	32,5	38	46,5	56,5	72	89	110	140	175
UB	45	52	60	70	90	110	130	170	170
XD	142	160	170	190	210	230	275	315	335
waga gr.	80	130	185	310	530	910	1710	2760	3880

Kołnierz tylny, męski (MP4)

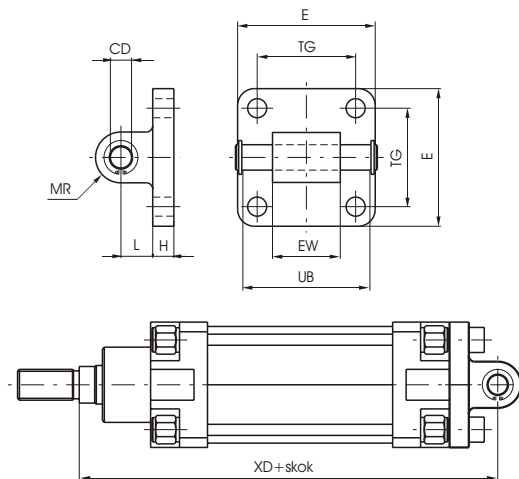

Kołnierz typu męskiego z trzpieniem. Siłownik mocowany równoległe lub pod kątem prostym do płaszczyzny. Tłoczek może oscylować i samoosiować się względem obciążenia. Wykonane z aluminium i pokryte czarnym lakierem.

Kod zamówieniowy	
	1320.Ø.09/1F

Średnica	32	40	50	63	80	100	125	160	200
CD (h 9)	10	12	12	16	16	20	25	30	30
E	45	52	65	75	95	115	140	180	220
EW (h ₂)	26	28	32	40	50	60	70	90	90
H	9	9	11	11	14	14	20	20	25
L	13	16	16	21	22	27	30	35	35
MR	10	12	12	16	16	20	25	25	25
TG	32,5	38	46,5	56,5	72	89	110	140	175
UB	46	53	61	71	91	111	132	171,5	171,5
XD	142	160	170	190	210	230	275	315	335
Waga g	90	130	190	340	580	960	1800	2830	3940

Wspornik kompletny kątowy (niewyspecyfikowany w standardzie ISO-VDMA)

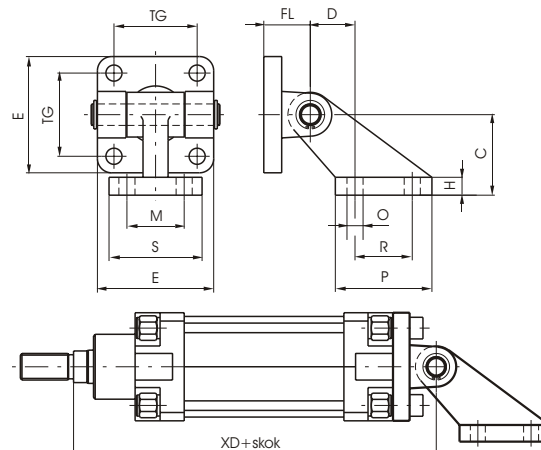

Mocowanie składa się z kołnierza 09 i stopy kątowej. Używane do montażu siłownika równoległe do płaszczyzny do której przymocowano stopę. Siłownik może oscylować aż do kąta 90 stopni względem płaszczyzny.

Kod zamówieniowy	
	1320.Ø.11F

Średnica	32	40	50	63	80	100	125	160	200
C (JS 15)	32	45	45	63	63	90	90	140	140
D	18	25	25	32	32	40	40	50	50
E	45	52	65	75	95	115	140	180	220
H	8	10	10	12	12	17	17	20	20
FL	22	25	27	32	36	41	50	55	60
M (JS 14)	25	32	32	40	40	50	50	63	63
TG	32,5	38	46,5	56,5	72	89	110	140	175
O (H13)	7	9	9	11	11	14	14	18	18
P (JS 14)	37	54	54	75	75	103	103	154	154
R	20	32	32	50	50	70	70	110	110
S	41	52	52	63	63	80	80	110	110
XD	142	160	170	190	210	230	275	315	335
Waga g	130	260	330	600	820	1560	2530	4735	5795

Wspornik kompletny kątowy

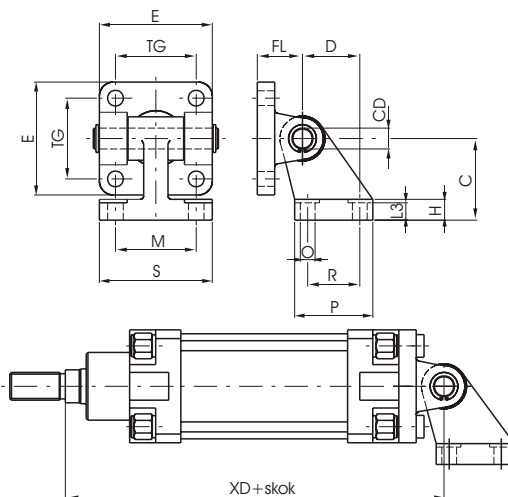

Średnica	32	40	50	63	80	100	125	160	200
E	45	52	65	75	95	115	140	180	220
TG	32,5	38	46,5	56,5	72	89	110	140	175
FL	22	25	27	32	36	41	50	55	60
D (JS14)	21	24	33	37	47	55	70	97	105
CD (H9)	10	12	12	16	16	20	25	30	30
C (JS15)	32	36	45	50	63	71	90	115	135
H	8	10	12	14	14	17	20	25	30
L3	6,4	8,4	10,4	12,4	11,5	14,5	16,8	21	26
R (JS14)	18	22	30	35	40	50	60	88	90
P	31	35	45	50	60	70	90	126	130
O (H13)	6,6	6,6	9	9	11	11	14	14	18
S	51	54	65	67	86	96	124	156	162
M (JS14)	38	41	50	52	66	76	94	118	122
XD	142	160	170	190	210	230	275	315	335
Waga g	120	180	225	435	730	1220	2325	3780	4950

Kod zamówieniowy

1320.Ø.35F

Wspornik kompletny

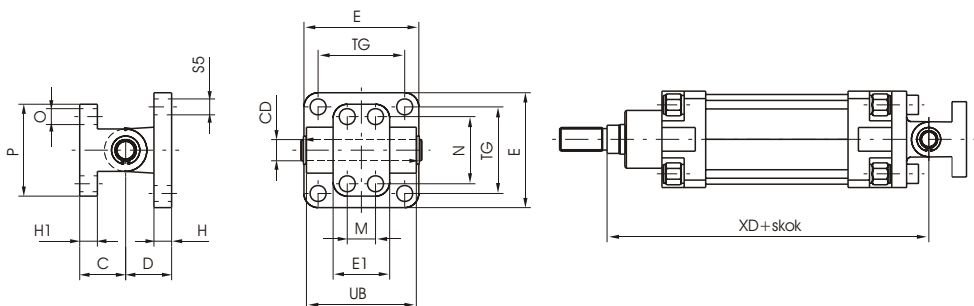

Mocowanie to składa się z kołnierza 09 i części wspornika. Używane do montażu siłownika pod kątem prostym do powierzchni do której on sam jest przymocowany. Umożliwia samoosiowanie się siłownika pod obciążeniem z oscylacją ± 60 stopni.

Średnica	32	40	50	63	80	100	125	160	200
C	18	26	26	34	34	41	41	55	55
CD	10	12	12	16	16	20	25	30	30
D	22	25	27	32	36	41	50	55	60
E	45	52	65	75	95	115	140	180	220
E1	25	32	32	46	46	56	56	71	71
H	10	10	12	12	16	16	20	20	25
H1	8	10	10	12	12	16	16	20	20
M	-	16	16	25	25	32	32	43	43
N	28	38	38	54	54	90	90	150	150
O	7	9	9	11	11	14	14	18	18
P	40	52	52	75	75	115	115	180	180
S5	6,6	6,6	9	9	11	11	14	18	18
TG	32,5	38	46,5	56,5	72	89	110	140	175
UB	45	52	60	70	90	110	130	170	170
XD	142	160	170	190	210	230	275	315	335
Waga g	110	190	240	490	710	1290	2090	3690	4810

Kod zamówieniowy

1320.Ø.10F

Kołnierz tylny - wąski

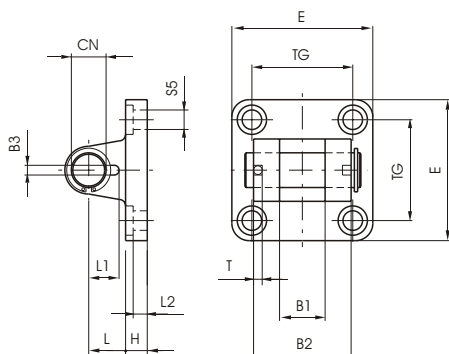
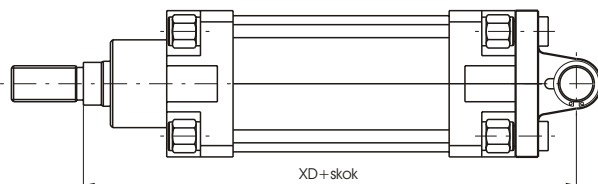

Gdy użyty łącznie z mocowaniem z przegubem kulowym 15F pozwala na duży stopień swobody oscylacji.

Wykonany ze stopu aluminium lakierowanego

Kod zamówieniowy

1320.Ø.30F

Średnica	32	40	50	63	80	100	125	160	200
B 1 (h 14)	14	16	21	21	25	25	37	43	43
B 2 (d 12)	34	40	45	51	65	75	97	122	122
B 3 (±0.2)	3,3	4,3	4,3	4,3	4,3	6,3	6,3	6,3	6,3
CN (H 7)	10	12	16	16	20	20	30	35	35
E	45	52	65	75	95	115	140	180	220
H	9	9	11	11	14	14	20	20	25
L	13	16	16	21	22	27	30	35	35
L 1 (±0.3)	11,5	12	14	14	16	16	24	26,5	26,5
L 2 (±0.5)	5,5	,5	6,5	6,5	10	10	10	10	11
S 5 (H 13)	6,6	6,6	9	9	11	11	14	18	18
T (±0.2)	3	4	4	4	4	4	6	6	6
TG	32,5	38	46,5	56,5	72	89	110	140	175
XD	142	160	170	190	210	230	275	315	335
Waga g	70	115	200	290	570	820	1710	3010	4380

Kołnierz tylny z przegubem kulowym (zgodne z normą DIN 648K)

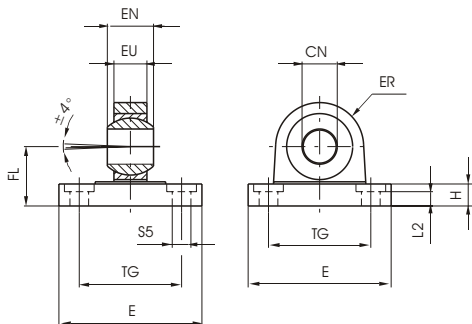
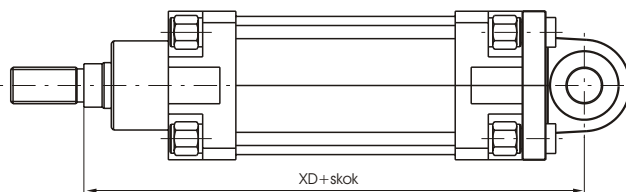

Gdy użyty łącznie z mocowaniem z przegubem kulowym 30F pozwala na duży stopień swobody oscylacji.

Wykonany ze stopu aluminium, lakierowany na czarno.

Kod zamówieniowy

1320.Ø.15F

Średnica	32	40	50	63	80	100	125	160	200
CN (H 7)	10	12	16	16	20	20	30	35	35
E	45	52	65	75	95	115	140	180	220
EN (-0.1)	14	16	21	21	25	25	37	43	43
ER	16	19	21	24	28,5	30	40	45	48
EU	10,5	12	15	15	18	18	25	28	28
FL (JS 15)	22	25	27	32	36	41	50	55	60
H	9	9	11	11	14	14	20	20	25
L 2 (±0.5)	5,5	5,5	6,5	6,5	10	10	10	10	11
S 5 (H 13)	6,6	6,6	9	9	11	11	13,5	18	18
TG	32,5	38	46,5	56,5	72	89	110	140	175
XD	142	160	170	190	210	230	275	315	335
Waga g	60	100	180	245	480	650	1410	2420	3840

Obejma wahlowa



Obejma wahlowa mocowana na profilu siłownika. Stanowi oś obrotu w wybranym punkcie pomiędzy pokrywami siłownika. Mocowane do tuleji kształtowej czterema śrubami imbusowymi. Uwaga: montaż obejmy wahlowej na styku z pokrywą nie pozwala na prawidłowe użycie czujnika jako sygnalizatora krańcowego.

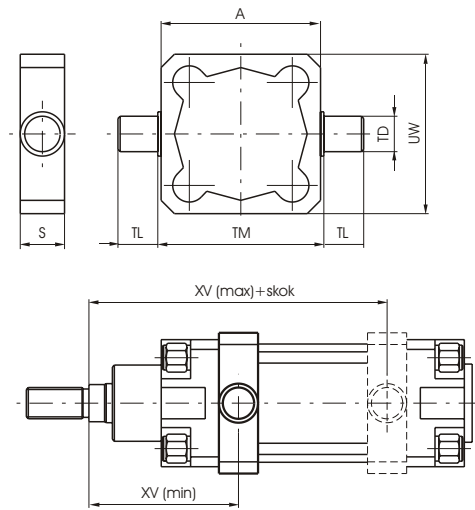

Średnica	32	40	50	63	80	100	125	160	200
A	49	62	73	87	109	130	155	190	240
S	18	21	21	27	27	32	32	40	40
TD (e 9)	12	16	16	20	20	25	25	32	32
TL (h 14)	12	16	16	20	20	25	25	32	32
TM (h 14)	50	63	75	90	110	132	160	200	250
UW	59	62	73	87	109	130	155	180	240
XV (max.)	85	96	102	109	123,5	131,5	162	193	204
XV (min.)	61	69	78	86	96,5	108,5	128	150	168
Waga g	180	270	330	650	890	1550	1950	3580	5850

Kod zamówieniowy
1320.Ø.12F

Wspornik do obejmy wahlowej

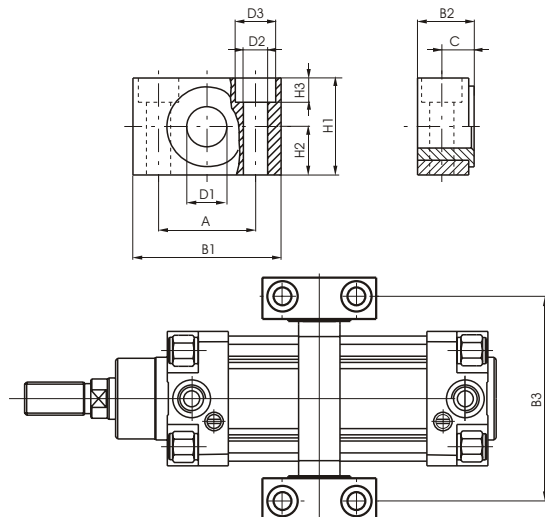
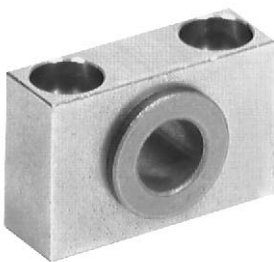

Dwa wsporniki pozwalają na montaż obejmy z siłownikiem na płaszczyźnie.

Średnica	32	40	50	63	80	100	125	160	200
A (±0,2)	32	36	36	42	42	50	50	60	60
B1	46	55	55	65	65	75	75	92	92
B2	18	21	21	23	23	28,5	28,5	40	40
B3	71	87	99	116	136	164	192	245	295
C	10,5	12	12	13	13	16	16	22,5	22,5
D1 (F7)	12	16	16	20	20	25	25	32	32
D2	6,6	9	9	11	11	14	14	18	18
D3	11	15	15	18	18	20	20	26	26
H1	30	36	36	40	40	50	50	60	60
H2 (±0,1)	15	18	18	20	20	25	25	30	30
H3	7	9	9	11	11	13	13	17	17
Waga g(1 element)	100	150	150	235	235	435	435	850	850

Kod zamówieniowy
1320.Ø.12/1F (1 element)

Główce widelkowe i nakrętki kontrolujące na tłoczysko

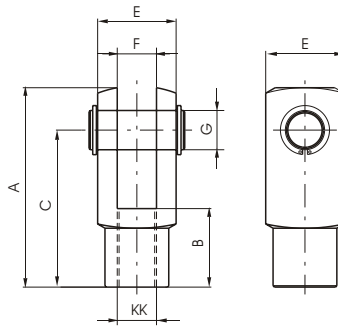

Kod zamówieniowy

1320.Ø.13F

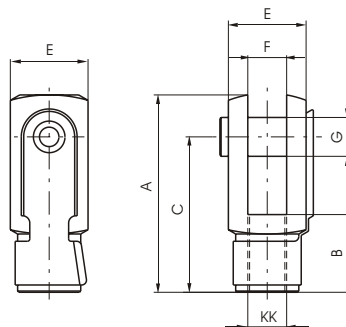
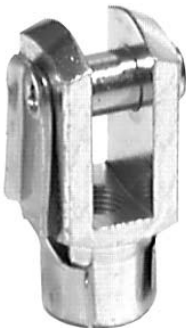

(od Ø 32 to Ø 100)

Kod zamówieniowy

1320.Ø.13/1F

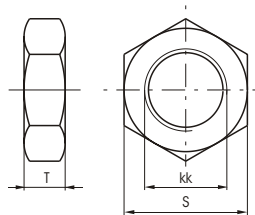

Kod zamówieniowy

1320.Ø.18F

Głowica widelkowa:
Zapewnia połączenie przegubowe tłoczyska z obciążeniem. Wykonana ze stali cynkowanej.

Nakrętka kontrolująca:
Blokuję głowicę widelkową.

Średnica	32	40	50	63	80	100	125	160	200	
A	52	62	83	83	105	105	148	188	188	
B	20	24	32	32	40	40	56	72	72	
C	40	48	64	64	80	80	110	144	144	
E	20	24	32	32	40	40	55	70	70	
F(B12)	10	12	16	16	20	20	30	35	35	
G	10	12	16	16	20	20	30	35	35	
S	17	19	24	24	30	2030	41	55	55	
T	6	7	8	8	9	9	12	18	18	
KK	M10X1,25	M12X1,25	M16X1,5	M16X1,5	M20X1,5	M20X1,5	M27X2	M36X2	M36X2	
Waga g.	Widelki	100	140	340	340	680	680	2500	4000	4000
	Nakrętka	15	20	20	20	40	40	100	210	210

Głowica z przegubem kulowym

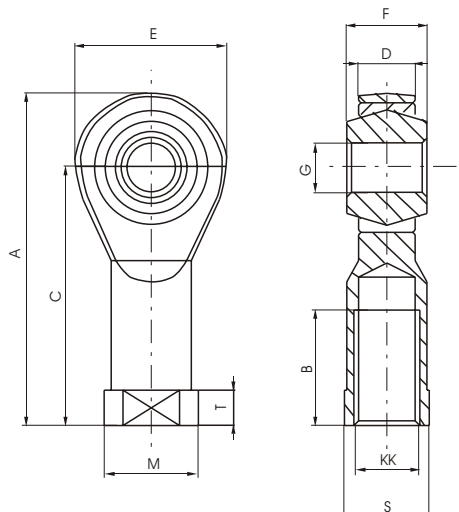

Średnica	32	40	50	63	80	100	125	160	200
A	57	66	85	85	102	102	145	165	165
B	20	22	28	28	33	33	51	56	56
C	43	50	64	64	77	77	110	125	125
D (-0,1)	10,5	12	15	15	18	18	25	28	28
E	28	32	42	42	50	50	70	80	80
F	14	16	21	21	25	25	37	43	43
G (H7)	10	12	16	16	20	20	30	35	35
KK	M10x1,25	M12x1,25	M16x1,5	M16x1,5	M20x1,5	M20x1,5	M27x2	M36x2	M36x2
M	19	22	27	27	34	34	50	58	58
S	17	19	22	22	30	30	41	50	50
T	6,5	6,5	8	8	10	10	15	17	17
Waga g	76	110	220	220	410	410	1200	1600	1600

Kod zamówieniowy

1320.Ø.32F

Połączenie samoosiujące

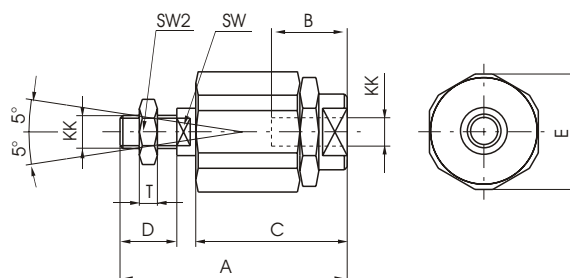

Średnica	32	40	50	63	80	100
A	71	75	103	103	119	119
B	20	20	32	32	40	40
C	46	46	63	63	71	71
D	20	24	32	32	40	40
E	32	32	45	45	45	45
KK	M10x1,25	M12x1,25	M16x1,5	M16x1,5	M20x1,5	M20x1,5
SW	12	12	20	20	20	20
SW1	19	19	30	30	30	30
SW2	17	19	24	24	30	30
SW3	30	30	41	41	41	41
T	6	7	8	8	9	9
Waga g	220	230	660	660	700	700

Kod zamówieniowy

1320.Ø.33F

Kołnierz tylny ze sworzniem (MP2)

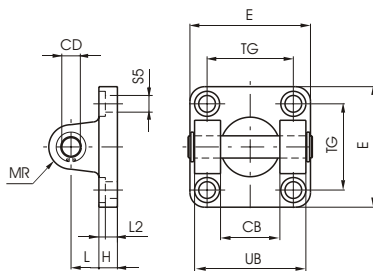
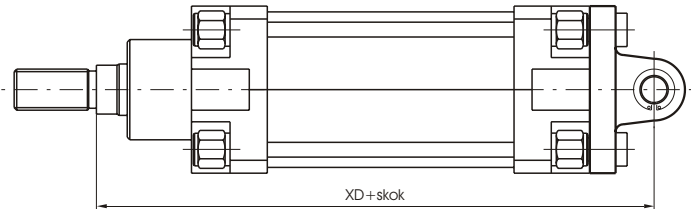

Średnica	32	40	50	63	80	100	125	160	200
CB (H 14)	26	28	32	40	50	60	70	90	90
CD (h 9)	10	12	12	16	16	20	25	30	30
E	45	55	65	75	95	115	140	180	220
H	10	10	10	12	14	16	20	20	20
L	12	15	17	20	22	25	30	35	40
L2 (±0.5)	5,5	5,5	6,5	6,5	10	10	10	10	11
MR	10	12	12	16	16	20	25	25	25
S5	6,5	6,5	9	9	11	11	13,5	18	18
TG	32,5	38	46,5	56,5	72	89	110	140	175
UB (h 14)	45	52	60	70	90	110	130	170	170
XD	142	160	170	190	210	230	275	315	335
Waga g	180	290	400	670	1160	2000	3890	6730	9880

Kod zamówieniowy

1320.Ø.20F

Kołnierz tylny ze sworzniem - męski (MP4)

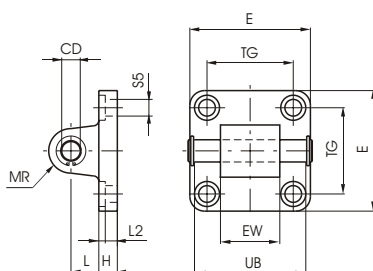
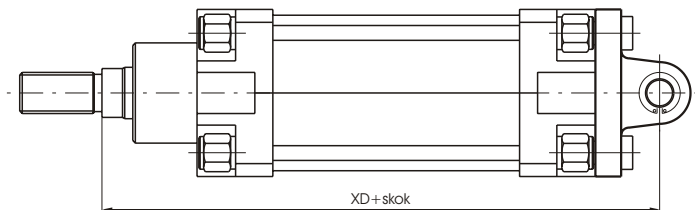

Średnica	32	40	50	63	80	100	125	160	200
CD (h 9)	10	12	12	16	16	20	25	30	30
E	45	55	65	75	95	115	140	180	220
EW ^(+0,2) _(-0,6)	26	28	32	40	50	60	70	90	92
H	10	10	10	12	14	16	20	20	20
L	12	15	17	20	22	25	30	35	40
L2 (±0.5)	5,5	5,5	6,5	6,5	10	10	10	10	11
MR	10	12	12	16	16	20	25	25	25
S5	6,6	6,6	9	9	11	11	13,5	18	18
TG	32,5	38	46,5	56,5	72	89	110	140	175
UB (h 14)	46	53	61	71	91	111	132	171,5	171,5
XD	142	160	170	190	210	230	275	315	335
Waga g	210	330	430	810	1350	2400	4300	6880	8560

Kod zamówieniowy

1320.Ø.21F

Wspornik kompletny - wersja stalowa

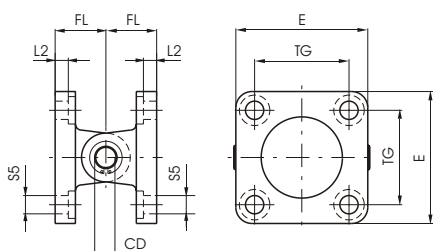
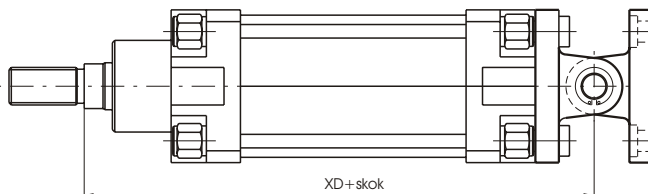

Średnica	32	40	50	63	80	100	125	160	200
CD (h 9)	10	12	12	16	16	20	25	30	30
E	45	55	65	75	95	115	140	180	220
FL	22	25	27	32	36	41	50	55	60
L2 (±0.5)	5,5	5,5	6,5	6,5	10	10	10	10	11
S5	6,6	6,6	9	9	11	11	13,5	18	18
TG	32,5	38	46,5	56,5	72	89	110	140	175
XD	142	160	170	190	210	230	275	315	335
Waga g	360	580	780	1370	2370	4110	7670	12650	17480

Kod zamówieniowy
1320.Ø.22F

Wspornik kompletny kątowy - wersja stalowa

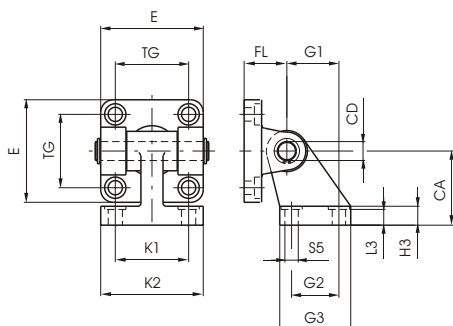
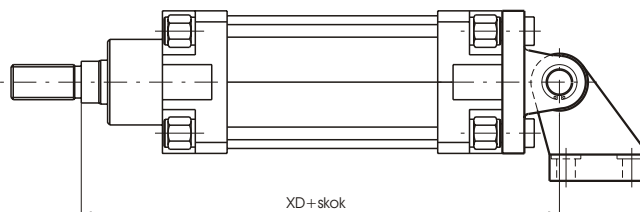

Średnica	32	40	50	63	80	100
CA (JS 15)	32	36	45	50	63	71
CD (h 9)	10	12	12	16	16	20
E	45	55	65	75	95	115
FL	22	25	27	32	36	41
G1 (JS 14)	21	24	33	37	47	55
G2 (JS 14)	18	22	30	35	40	50
G3	31	35	45	50	60	70
H3	8	10	12	12	14	15
K1 (JS 14)	38	41	50	52	66	76
K2	51	54	65	67	86	96
L3 (±0.5)	7,5	8	10	10	11	12
S5 (H 13)	6,6	6,6	9	9	11	11
TG	32,5	38	46,5	56,5	72	89
XD	142	160	170	190	210	230
Waga g	340	500	640	1250	2100	3500

Kod zamówieniowy
1320.Ø.23F

Kołnierz tylny - wąski

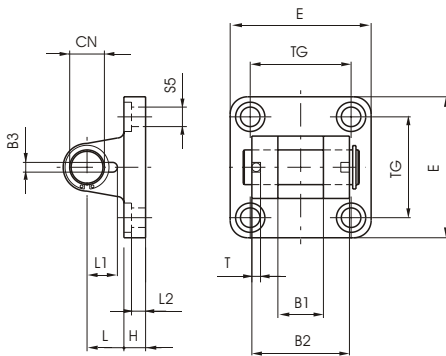
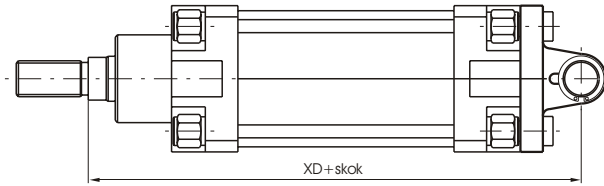

Średnica	32	40	50	63	80	100	125
B 1 ¹⁴⁾	14	16	21	21	25	25	37
B 2 ¹²⁾	34	40	45	51	65	75	97
B 3 ^{0 2)}	3,3	4,3	4,3	4,3	4,3	6,3	6,3
CN (H 7)	10	12	16	16	20	20	30
E	45	55	65	75	95	115	140
H	10	10	10	12	14	16	20
L	12	15	17	20	22	25	30
L 1 ^{0 3)}	11,5	12	14	14	16	16	24
L 2 ^{0 5)}	5,5	5,5	6,5	6,5	10	10	10
S 5 ^{1 3)}	6,5	6,5	8,5	8,5	10,5	10,5	13
T (±0 2)	3	4	4	4	4	4	6
TG	32,5	38	46,5	56,5	72	89	110
XD	142	160	170	190	210	230	275
Waga g	160	270	370	670	1110	2100	4150

Kod zamówieniowy

1320.Ø.29F

Kołnierz tylny męski

(z przegubem kulowym zgodny z normą DIN 648K)

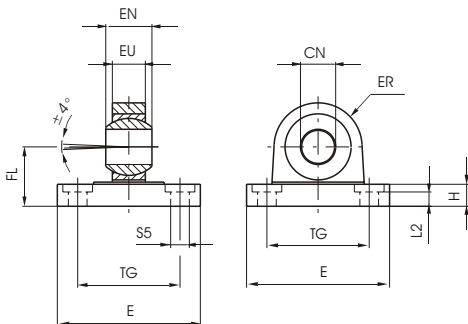
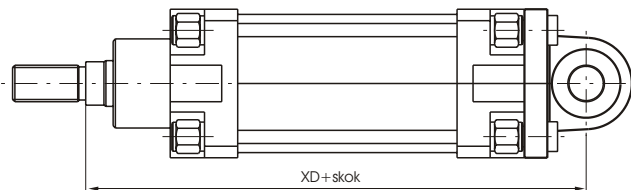

Średnica	32	40	50	63	80	100	125
CN (H 7)	10	12	16	16	20	20	30
E	45	55	65	75	95	115	140
EN (0 1)	14	16	21	21	25	25	37
ER	15	18	20	23	27	30	40
EU	10,5	12	15	15	18	18	25
FL (S 15)	22	25	27	32	36	41	50
H	10	10	10	12	14	16	20
L 2 ^{0 5)}	5,5	5,5	6,5	6,5	10	10	10
S 5 ^{1 3)}	6,5	6,5	8,5	8,5	10,5	10,5	13
TG	32,5	38	46,5	56,5	72	89	110
XD	142	160	170	190	210	230	275
Waga g	210	310	400	710	1350	2400	4000

Kod zamówieniowy

1320.Ø.25F

Wspornik kompletny

(z głowicą kulową, zgodny z normą DIN 648K)

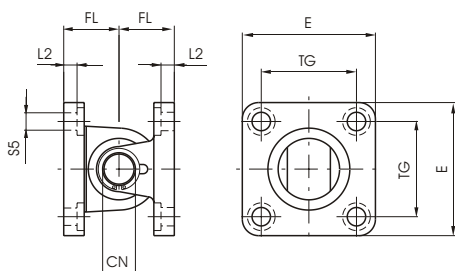
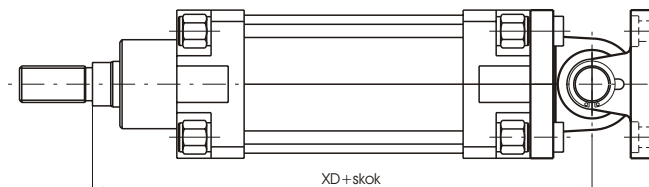

Kod zamówieniowy
1320.Ø.26F

Średnica	32	40	50	63	80	100	125
CN (H 7)	10	12	16	16	20	20	30
E	45	55	65	75	95	115	140
FL (±0,2)	22	25	27	32	36	41	50
L2 (±0,5)	5,5	5,5	6,5	6,5	10	10	10
S5 (H 13)	6,5	6,5	8,5	8,5	10,5	10,5	13
TG	32,5	38	46,5	56,5	72	89	110
XD	142	160	170	190	210	230	275
Waga g	380	580	770	1380	2460	4500	7700

Wspornik kompletny kątowy

(z głowicą kulową, zgodny z normą DIN 648K)

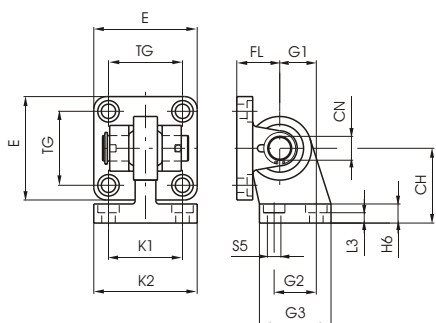
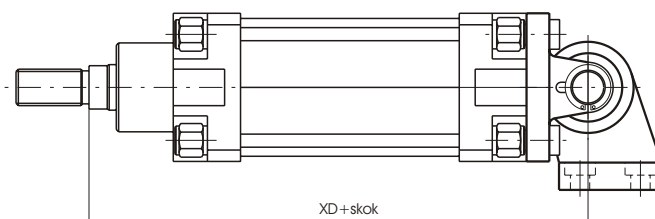

Kod zamówieniowy
1320.Ø.27F

Średnica	32	40	50	63	80	100	125
CH (S 15)	32	36	45	50	63	71	90
CN (H 7)	10	12	16	16	20	20	30
E	45	55	65	75	95	115	140
FL (S 15)	22	25	27	32	36	41	50
G 1 (S 14)	21	24	33	37	47	55	70
G 2 (S 14)	18	22	30	35	40	50	60
G 3	31	35	45	50	60	70	90
H (6)	10	10	12	12	14	15	20
K 1 (S 14)	38	41	50	52	66	76	94
K 2	51	54	65	67	86	96	124
L (S 0,5)	7,5	8	10	10	11	12	17
S (S 13)	6,6	6,6	9	9	11	11	13
TG	32,5	38	46,5	56,5	72	89	110
XD	142	160	170	190	210	230	275
Waga g	330	480	830	1220	2100	3580	7000