

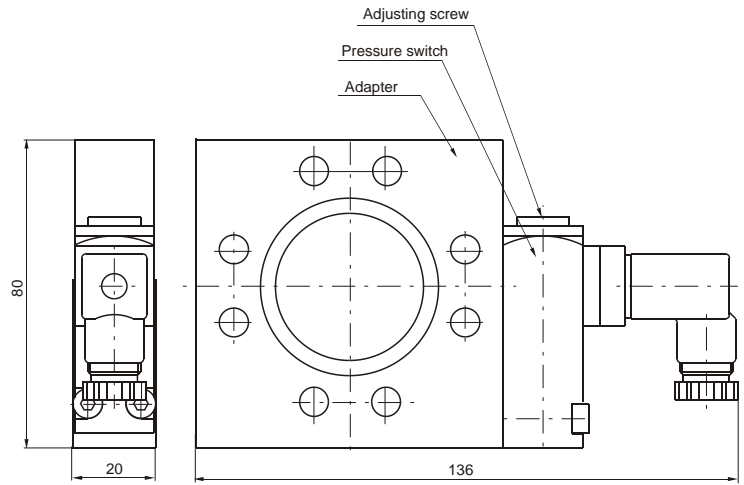

Pressure switch complete with adapter



Construction and working characteristics

The pressure switch complete of adapter has to be assembled between two elements of the FRL group. It cannot be utilized separately or at the end of the FRL group.

The pressure switch can be set at desired pressure (pressure range from 2 to 10 bar) by rotating the adjusting screw.

The electrical connection is made by mean of a 15 mm connector DIN 43650 type C.

The microswitch contact could be normally closed or open (change over switch).

Connection

- 1 = Neutral
- 2 = N.C. contact
- 3 = N.O. contact

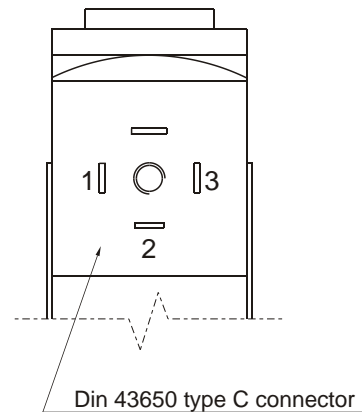

Technical characteristics

Max. inlet pressure	13 bar 1,3 MPa
Max. temperature	50°C
Weight	gr. 450
Microswitch capacity	5A
Grade of protection (with connector assembled)	IP65
Adjusting range	2 - 10 bar
assembly position	Any

Ordering code

17

- 44A = Pressure switch adapter
- 14B = Pressure switch
- 44C = Pressure switch complete with adapter

Example: **1744C**
Pressure switch complete with adapter.



Air intake

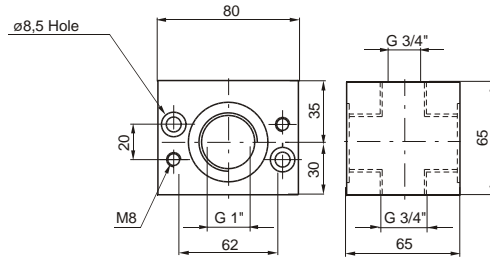

Weight 450 gr.

Ordering code

17440

Pressure gauge

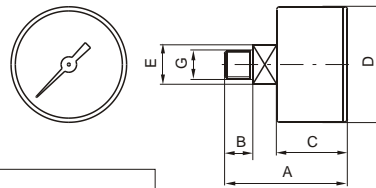

DIMENSIONS							
CODE	A	B	C	D	E	G	Weight gr.
17070A	44	10	26	41	14	G1/8"	60
17070B	45	10	27	49	14	G1/8"	80

Ordering code

17070

A = Dial \varnothing 40
B = Dial \varnothing 50

A = Scale 0-4 bar
B = Scale 0-6 bar
C = Scale 0-12 bar

Assembling kit



Weight 45 gr.

Ordering code

17460
(standard)

17465
(for progressive start-up valve)